

(The Meeting is Being Recorded for Posting Online)

COVID-19: Guidance for the UD Research Community

Virtual Town Hall

Monday, June 1, 2020

1–2 pm



COVID-19: Guidance for the UD Research Community

BEGINNING
JUNE 2020

Research Reactivation Phase 1

Creating a More Just Society



A Message from President Assanis

The Indomitable Class of 2020

Virtual Celebration

Held

Saturday, May 30th



COVID-19: Delaware

Data reported 5/31/20

State of Delaware

9,498

99.0 per 10,000 people

160

Hospitalized

5,266

Recovered

366

Deaths

51,173

Tested Negative



Current Hospitalizations

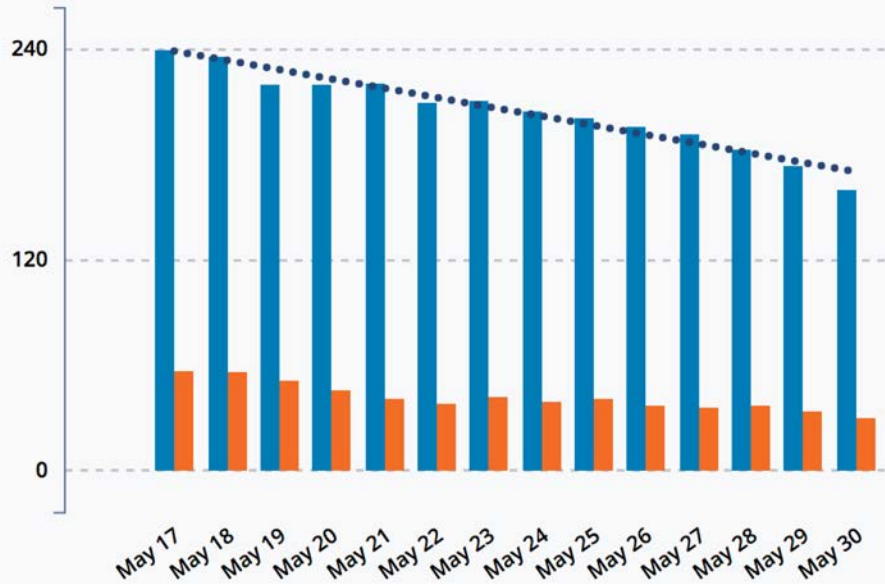

■ Current Hospitalizations (State of Delaware)
 ■ Current Hospitalizations (Sussex County)
 ●● Trend Line

New Hospital Admissions (Confirmed and Suspected with COVID-19)

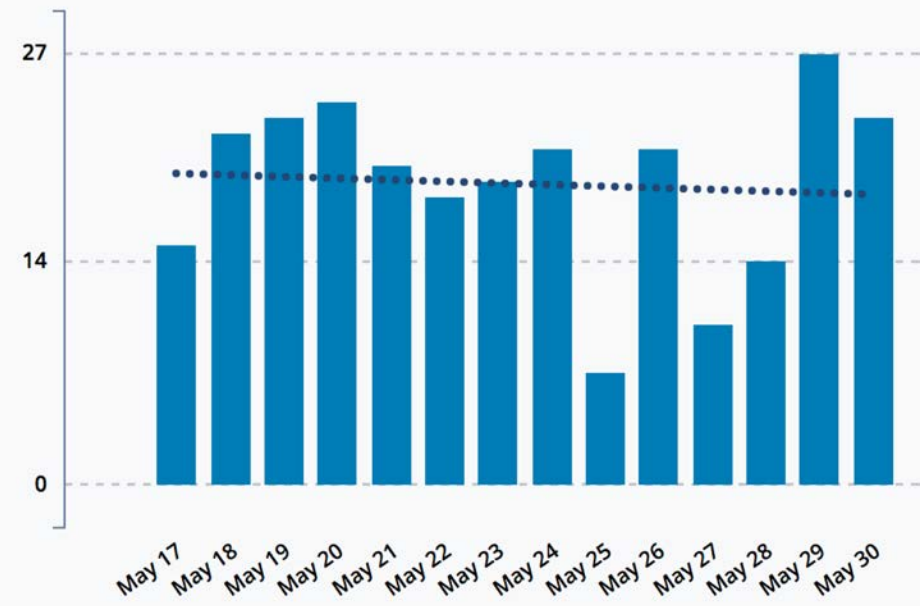





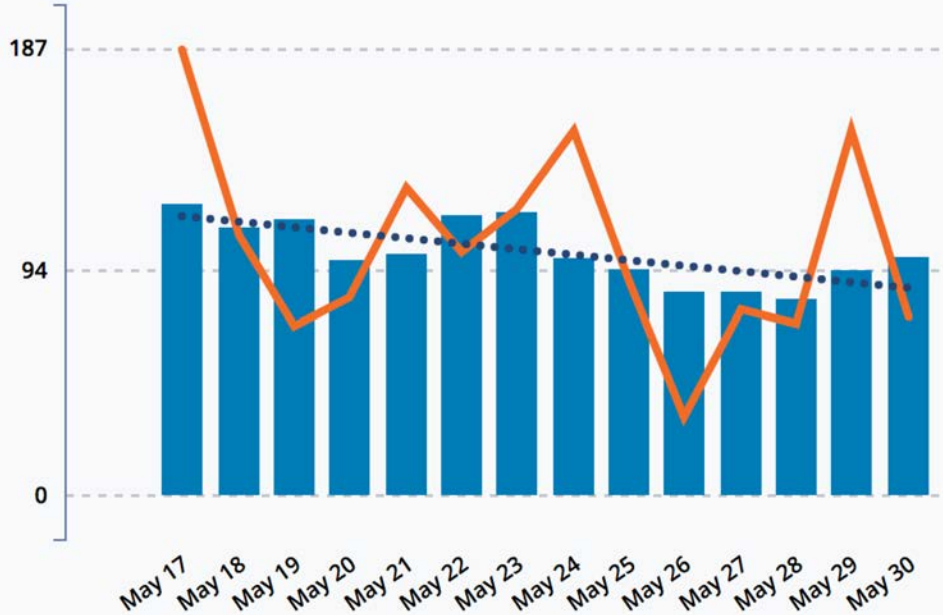

■ New Hospital Admissions
 ●● Trend Line

COVID-19: Delaware

New Positive Cases



| | | | |
|---|--|---|---|
|  | Fluid Resistant Gowns and Isolation Gowns 2 Weeks+ Left (Stable) |  | Face Shields 2 Weeks+ Left (Stable) |
|  | Glasses and Goggles 2 Weeks+ Left (Stable) |  | Gloves 2 Weeks+ Left (Stable) |
|  | Isolation and Procedural-Ear Loop Masks 2 Weeks+ Left (Stable) |  | N95 Masks 2 Weeks+ Left (Stable) |
|  | Surgical Masks 2 Weeks+ Left (Stable) | | |

■ Average
 — New Cases
 ●● Trend Line

State of Delaware–Phase 1

Vulnerable individuals **shelter in place**

Maintain **social distancing in public**

Schools and youth activities **remain closed**

Limit gatherings to **10 individuals**

Minimize non-essential travel – personal & business

Encourage **teleworking**

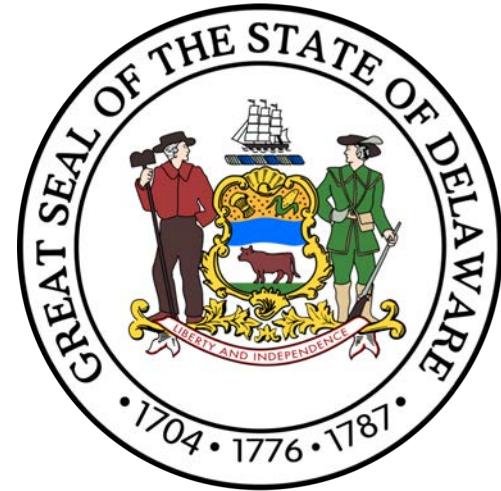

COVID-19 Testing in Delaware



State of Delaware has partnered with Curative, Inc.

Drive Thru Events are being held throughout the state

Friday at STAR Campus, 437 UD Employees

Additional Events are being planned and will be announced

Molecular Test Based on Saliva Swab

UD Campus Update

May 31st Updates

UD is extending its remote work plan for most employees until **July 15th**.

UD COVID-19 Return to Campus Guidelines

Employees and students may not return to campus unless specifically directed to do so by their supervisor or another authorized department, and guidance may change at any time as conditions and/or circumstances warrant.



UD Campus Update

May 8th Updates

UD has already moved **summer classes online** and deferred or **virtualized summer events and programs** on campus.

[Campus Reopening and Fall Planning Task Force](#)

[UD's Health Protocol & Policy Committee](#)

Campus-wide committees that will consider academic & calendar aspects, research & graduate education, student life & athletics, facilities, budget & planning, and public affairs.



UD Campus Update

Summer Parking

Parking Services is providing prorated refunds and the cancellation of all payroll deductions for Summer 2020.

Parking permit payroll deductions will not be taken **in June or July.**

Parking permits will not be cancelled, and **your lot assignment will remain the same** when we return to normal operations.

Shuttle Buses will not operate during the summer.

Use general parking spaces— Pearson, Hollingsworth, garages.

As always, parking permit renewal starts the **first business day of August.**



UD Campus Update

Student Financial Relief

Did you submit a FAFSA for this year? If so, CARES Act emergency grants have arrived and there may be money in your "My Finances" account right now!

Those who **submitted a FAFSA must log into My Finances** and request a dispersion of any available CARES Act funds by **June 1** or the funds will be redistributed to other students in need.

Those who were not able to submit a FAFSA, or were otherwise ineligible for a CARES grant, can apply for the [Student Crisis Fund](#).

Planning for the Future

Applicable to ALL UD research activities, regardless of site: on-campus, in the field and at partner sites, i.e. UD-owned and -operated, e.g. Winterthur, nat'l lab, agricultural sites, in schools, etc.

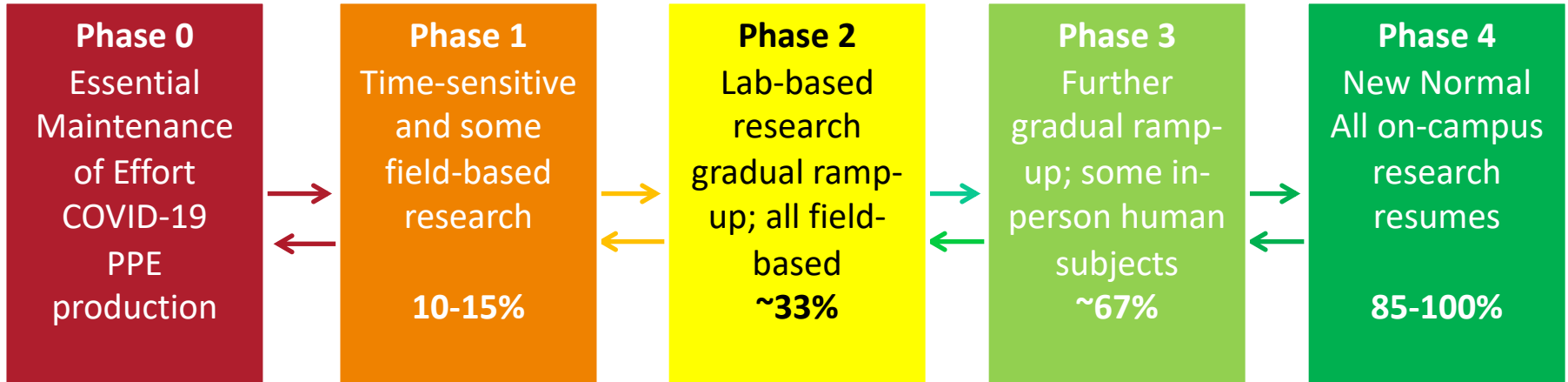

Working remotely whenever possible

Phasing in Research

Phase 1

Time-sensitive
and some field-
based research

10-15%

Disruption of effort/data collection causes catastrophic data loss or delays

Seasonal data collection, field/agricultural work

Long-term longitudinal studies

Animal experiments where a delay would result in euthanasia or loss of a colony

Risk Mitigation

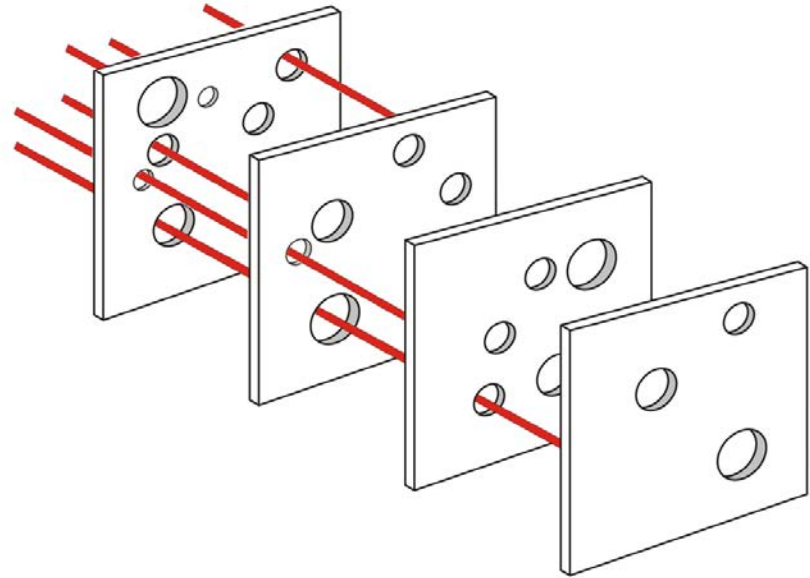
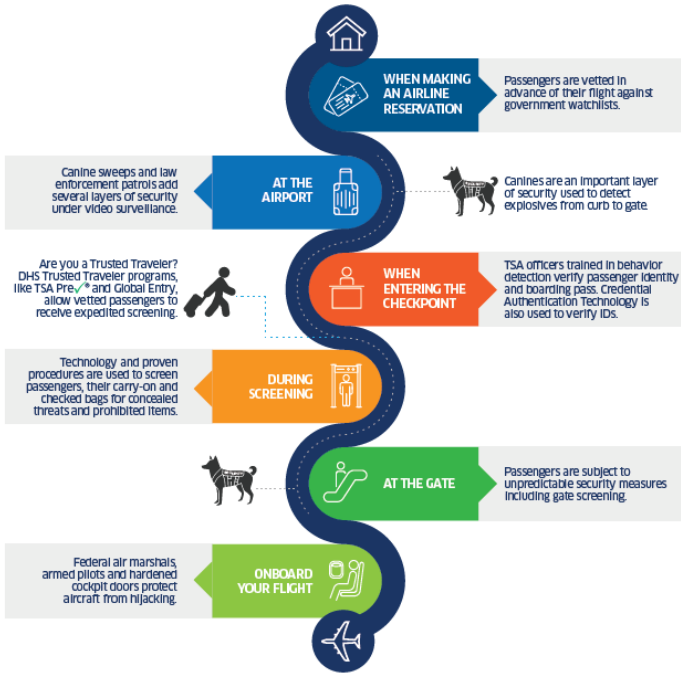

IF YOU SEE SOMETHING, SAY SOMETHING®
You are an important layer of security. Securing the aviation system takes everyone from the traveling public to merchants. Not On Our Watch!

COVID-19 Risk Mitigation

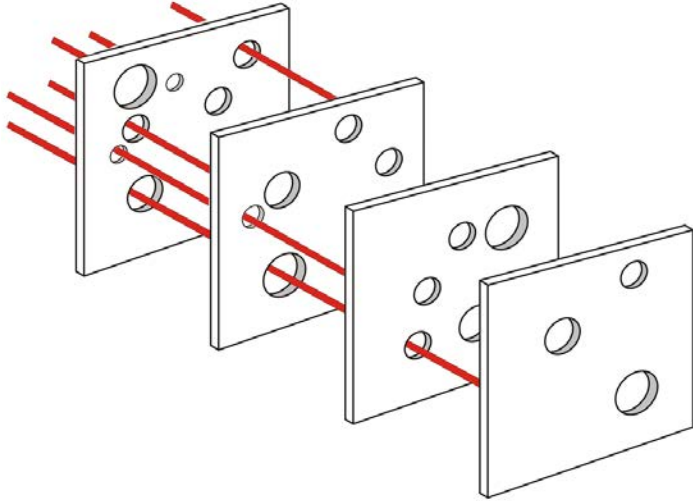

- Health screening
- Temperature checks
- Physical distancing
- Hand washing
- Cloth masks
- Testing
- Contact tracing
- Isolating
- Quarantining

UD's Return to Research under COVID-19

[RETURN TO CAMPUS GUIDANCE](#)
[PI RETURN TO CAMPUS FORM](#)
[RAMP-UP CHECKLIST](#)

Guidelines & Resources

The University of Delaware is working to resume research operations — with the safety and wellbeing of the community our highest priority. *All research work that can be performed remotely should continue remotely until further guidance is issued.* This page provides an overview of UD's phased-in return to research, in alignment with state and University guidance. It draws from a comprehensive plan developed with broad input from a working group including representatives from colleges, institutes, core facilities, environmental health and safety, communications, maintenance and operations.

Here, UD researchers also will find **required** forms that must be approved and access to training materials that must be completed **prior** to returning to campus, field-based or site-based research. A phased-in approach is being implemented. Review the phases below. If you think you (and your

| UD Research Ramp-Up | |
|---|-------------------|
| Principles | + |
| Expectations | + |
| Research Space Categories and Definitions | + |
| Health Screening Protocols | + |
| PPE Requirements | + |
| Physical Distancing | + |
| Protecting Vulnerable Populations | + |
| Facilities | + |

PI Return to Campus Request Form

Ramp-Up Checklist

Training

All employees must complete required safety training

UD Workplace Guidelines

Home Health Screening

Campus Reopening and Planning

Research Ramp-Up Phases

Click on each phase for more details. We are now reviewing PI request forms for Phase 1.

▶ PHASE 0

CURRENT PHASE

• Essential Maintenance of Effort • COVID-19 PPE Production
THE RESEARCH COMMUNITY



▶ PHASE 1

ACTIVE PHASE/JUNE

• Time-Sensitive Research
• Some Field-Based Research

10-15%

OF THE RESEARCH COMMUNITY

▶ PHASE 2

TIMELINE TBD

• Lab-Based Research Gradual Ramp-Up • All Field Based

~33%

OF THE RESEARCH COMMUNITY

▶ PHASE 3

TIMELINE TBD

• Further Research Gradual Ramp-Up • Some In-Person Human Subjects

~67%

OF THE RESEARCH COMMUNITY

▶ PHASE 4

TIMELINE TBD

• New Normal • All On-Campus Research Resumes

85-100%

OF THE RESEARCH COMMUNITY

Planning for Phase 1

Guidance for PIs

Complete laboratory ramp-up checklist (as applicable) prior to accessing campus.

Ensure all training and certifications are up to date for all employees and students before returning to campus.

Speak individually with each coworker about their situation/concerns for re-start.

Group calendaring to ensure **physical distancing** and **shift work**, as needed.

Ensure you and all coworkers are completing the **daily health screen** before coming to work.

Planning for Phase 1

Guidance for PIs

Procure **multiple cloth masks** for each coworker. Wash daily.

PPE is being procured centrally. Contact either Fisher Storeroom (karen.black@thermofisher.com, 831-2285) or Mike Gladle, EHS Director (mgladle@udel.edu).

Check with your department chair or building manager to **confirm return date**.

Continue to work remotely as much as possible.

Planning for the Future

How Will Campus Be Different?



Daily health questionnaire

Cloth masks are the norm

Access to buildings/facilities will be highly controlled

Common areas/shared spaces remain closed

Lower density places greater emphasis on safety protocols

Planning for the Future

Communication is Key

We are in this together; take care of one another

Individual accountability and responsibility

“See something, say something”

Resources for students—advisor, program director, chair, Graduate College

Resources for staff—supervisor, unit lead, Human Resources

[Disability Support Services](#)

[Compliance Hotline](#)

Research Communications

What research are you doing on COVID-19?

What innovative approaches are you taking to working remotely?

What ways are you reaching out to the K-12 community? If you are participating in Skype a Scientist or a related program, please contact us

Email Tracey Bryant, Sr. Director for Research Communications, tbryant@udel.edu or your college communicators.

#UDFromHome
UD researchers share experiences and inspirations for moving forward while staying at home.

UD Research
Reactivating #UDel's research enterprise will be a gradual process, focused on safety and aligned with state COVID19 guidelines. Phase 1 is limited to 10-15% of researchers, those doing time-sensitive work, in an effort to prevent catastrophic data loss.
<https://t.co/5co9YKGSJf>
<https://t.co/rqyA1t6of7q>

UD Research
#UDel's Tyler Van Buren and collaborators have developed a way to monitor #blood damage in real time.
<https://t.co/tHGVGv50wb>
@UEngineering
@TylerVBuren
#fluidmechanics
<https://t.co/Dn2Hjaopua>

Virtual Town Hall
Mondays — 1-2p.m.
The Research Office will host a Virtual Town Hall Monday June 1, 1-2 p.m., for important updates for the research community.

Doug White
A doctor in scrubs just stopped by and snagged a handful of ear savers to bring to his coworkers at the hospital.
#UDFromHome
<https://t.co/ppmf78i97f>

How Can You Help?

Many of our alumni, parents and friends have asked how they can help during this unprecedented time for the University community.

- [Blue Hen Strong Fund](#)
- [COVID-19 Employee Emergency Relief Fund](#)



Supporting Our Community

- Students can contact the Center for Counseling & Student Development at (302) 831-2141 or (302) 831-1001 for after-hours emergencies, or Student Health Services at (302) 831-2226.
- Faculty and staff may contact the Employee Assistance Program within Human Resources at (302) 831-2171 and/or their health care provider.



*Tim Dowling, Director
Student Health Services*



*Jennifer Horney, Founding Director
Program in Epidemiology*



*Mike Gladle
Director*

*Environmental Health
& Safety*



*Sylvester Johnson
Director*

Custodial & Univ. Services



*Paul Dickinson
Director*

Maintenance & Operations

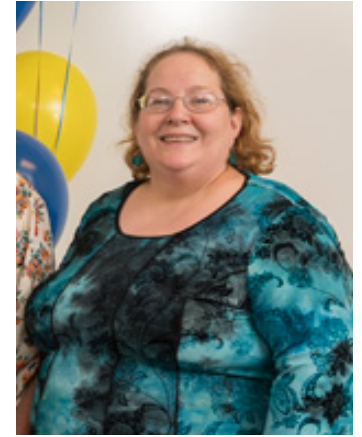

*Judy David
Assoc. Director
Custodial & Univ. Services*



Dave Martin
COE



Murray Johnston
CAS



Eric Wommack
CANR



Laura Desimone
CEHD



Sheryl Kline
LCBE



Fabrice Veron
CEOE



Dave Edwards
CHS



*Tracey Bryant, Sr. Director
Research Communications*



*David Barczak
Communications Manager*

Questions



Submit your questions
via the Zoom Chat

**Beginning this week –JUNE 1st
Town Halls will be held Mondays, 1-2 pm**